

## ADAPTIVE CONTROL SYSTEM OF LIGHT BEAM POSITION OF TRAM'S HEAD LIGHTS

**Krzysztof Stypulkowski**

*Warsaw University of Technology, Transport Department  
75 Koszykowa Street, 00-662 Warsaw, Poland  
phone: +48 22 2347752, fax: +48 22 4256543  
e-mail: kst@it.pw.edu.pl*

### **Abstract**

*The article proposes and discusses the application of AFS system in trams.*

*The author of the present publication substantiates the need of introducing the solution of foreground lighting of a vehicle, which has already proved effective for motor vehicles, taking into account the specificity of movement of a tram being one of the main means of transport within the framework of urban public transport system.*

*Using the results of laboratory photometric measurements for currently used optical light systems of tram's head lights, a proposal for the use of new light beams has been presented.*

*The method of realization of adaptive system of light beam control of tram's head lights has also been demonstrated.*

*In relation to the current photometric requirements in standardization guidelines concerning head lighting of a tram, directions of changes have been proposed.*

*Light beam shape of main lights in tram's foreground defined by isolux range, proposal of automatic light beam control system of a tram, proposal of arrangement of system reflectors within the area of tram car's front are presented in the paper.*

**Keywords:** *transport, tram, simulation, lighting distribution, tram lighting, front lighting*

Tram as a track means of public transport in cities is growing in popularity because of its role in reducing traffic congestion. Taking into consideration the abovementioned merits of this means of transport, it is crucial to make it more attractive by improving its comfort and safety.

The factor which influences the safety of track vehicle movement is the quality and state of tram's head lighting system. Proper distribution of a light beam within the area of tram's foreground plays a decisive role in luminous sensation perception by a tram driver. A correctly shaped and directed light beam conditions proper visibility from a tram driver's seat, and facilitates proper assessment of situations on the road connected with the behaviour of other road traffic participants.

Introduction of new lighting system of a tram car's foreground will increase the level of tram's active safety, and it will influence the increase of road traffic safety at night time regardless of weather conditions.

Analysing sample statistical data from the year 2006 [4] concerning road traffic incidents, it can be concluded that the problem of road traffic safety is important. In the year 2006, there were 65 accidents within sectioned off tram line area, in which 8 people died and 91 were injured. In the same year, there were 63 accidents which took place within the area of tram line not sectioned off. In these incidents, one person died and 86 sustained injuries. Another dangerous place of road traffic incidents is a public transport stop. In the year 2006 within the area of a public transport stop, there were 467 accidents, in which 34 people died and 544 were injured. Within the area of pedestrian crossings there were 4461 accidents, in which 301 people died and 4494 sustained injuries. Statistical data concerning accidents within the areas of public transport stops and pedestrian crossings does not make it clear how many of these accidents can be directly or

indirectly linked with trams. Other statistical data under analysis concerns the perpetrator of accident. In the year 2006 in Poland, 79 accidents were reported, the perpetrator of which was a tram driver. As a result of these road traffic incidents, 5 people died and 154 were injured. In the year 2007, 66 incidents of this kind were reported, in which 5 people died and 123 were injured [5]. Statistical data under analysis does not take into account the causes of road traffic incidents, it fails to make it clear in which of these incidents lighting and its quality was a direct or indirect cause of accidents.

Conducting conceptual work on adaptive control system of light beam position of tram's head lights, a series of laboratory tests were performed as well as field measurements, in order to determine lighting requirements to ensure optimal lighting of tram's foreground.

Another stage of work on adaptive control system of light beam position of tram's head lights is research currently being conducted aiming at determining optimal lighting parameters of tram's foreground. The purpose of these activities is to draw up assumptions and consequently drawing up a method of lighting quality assessment in tram's foreground.

In Fig. 1 and 2, examples of light beam exploitation are presented, for which isoluxes of the value of 1 are indicated defining range and shape of a light beam in accordance with requirements adopted for motor vehicles lighting technology [3].

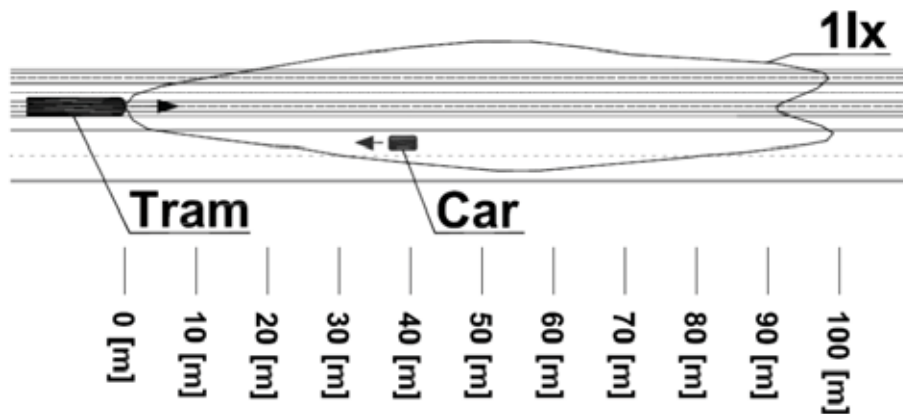

Fig. 1. Light beam shape of main lights in tram's foreground defined by isolux range of the value of 1

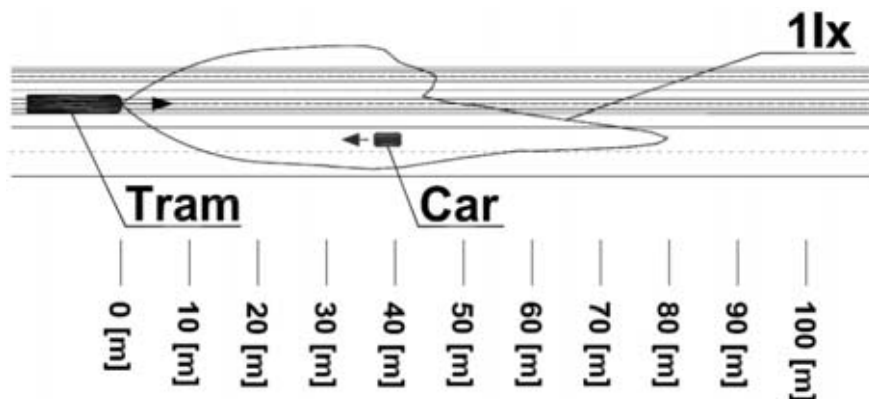

Fig. 2. Light beam shape of low beam lights in tram's foreground defined by isolux range of the value of 1

Results of laboratory photometric measurements of currently used optical-lighting systems of tram's head lights constituted the basis for the conducted analysis of the current state of tram's foreground lighting. Conclusions and observations from conducted researches and analyses were used for modelling new dedicated light beams of tram's head lights. What follows from these researches is the problem of lack of adjustment of currently used light beams to tasks they are supposed to fulfil taking into account the conditions of tram's movement. Road situation presented

in Fig. 1 and 2 is a case of glare effect on a driver of a vehicle coming from the opposite direction, resulting from mutual positioning of a tram line and road lane assigned for other vehicles.

In order to improve the present quality state of tram's foreground lighting, it is proposed to implement three possible variants of adaptive control system of light beam position of tram's head lights.

The first proposal consists in exchanging currently used reflectors and projectors in trams. A tram driver carries out head lighting control on the same basis as before. In this version of the system, electric auxiliary circuits of a tram car are not interfered with.

Redesign is proposed in this solution in order to adjust to tram's needs the two basic light beams of low beam and main lights. Proposals of these beams taking into consideration luminous flux density on a tram line and road surfaces (tram's foreground) for low beam and main lights are presented in Fig. 3 and 4.

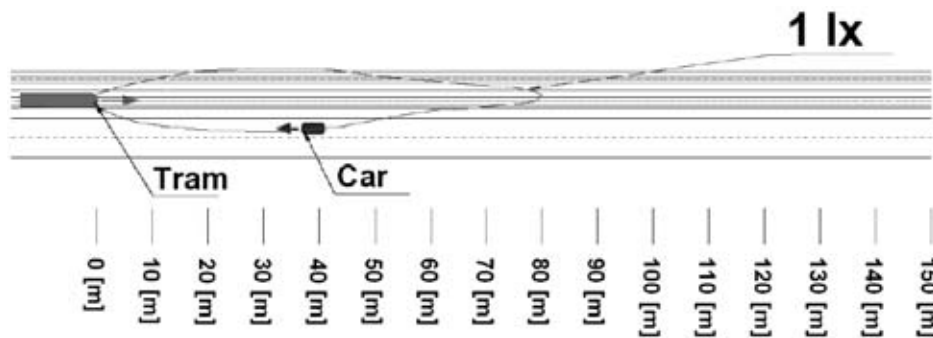

Fig. 3. Light beam shape of main lights in tram's foreground defined by isolux range of the value of 1 – proposal

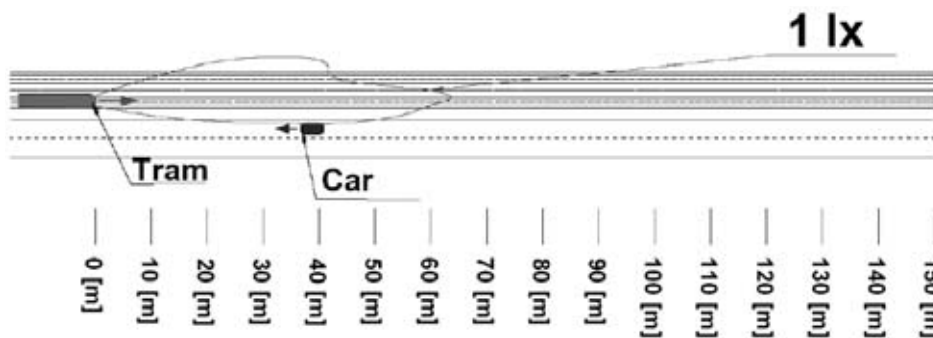

Fig. 4. Light beam shape of low beam lights in tram's foreground defined by isolux range of the value of 1 – proposal

Both proposals of light beams are characterised by limiting the width of light distribution in horizontal plane and increasing beam's range in relation to the existing solutions.

Directing low beam light beam towards tram's trajectory ensures limiting disadvantageous emission towards a motor vehicle coming from the opposite direction. This can influence limiting the glare of a driver of a vehicle coming from the opposite direction. Limiting the width of main light beam distribution still ensures indispensable visibility to a tram driver within the area of tram's foreground. Proposed parameters of a light beam also ensure safe distance for stopping a tram.

The first variant of light beam control system and control of light beam position has an undeniable advantage which consists in adjusting parameters of tram's head light beam to urban traffic conditions. This solution is first of all dedicated to tram cars of older construction, in which the improvement of lighting parameters of tram's foreground can be achieved by means of lower financial outlays exchanging currently used reflectors into reflectors or projectors with new dedicated beams. This proposal takes into account, first and foremost, potential term of further exploitation of tram cars produced in the sixties and seventies, as well as costs connected with this procedure.

The second proposal concerns equipping newly produced and modernised tram cars with a smart front lighting system. In this solution, the system of head reflectors is enriched with a module automatically adjusting the lighting to tram movement conditions.

This proposal suggests exchanging currently used lighting equipment into the new one with dedicated light beams for main and low beam lights, as well as equipping a tram car with additional two reflectors of curve lights. Curve lights are automatically switched on when an indicator is switched on and when the control system of light beam position of tram's head lights recognizes a bend of the road.

In this version of the system, lighting equipment has fixed directed light beams. Control system offers two modes of operation: manual and automatic. In the case of automatic mode, a control unit on the basis of self-locating procedure works out decisions which light beam, when and for how long is switched on. In the case of manual mode, it is a tram driver who decides which lighting equipment is active.

Proposal of light beams of main, low beam and curve lights are presented in Fig. 5-7. For the proposals of a light beam of curve lights, a minimal binding radius of tram line's curve arc of the value of 25 m was adopted. In this solution, reflectors of curve lights direct the beam at a fixed angle.

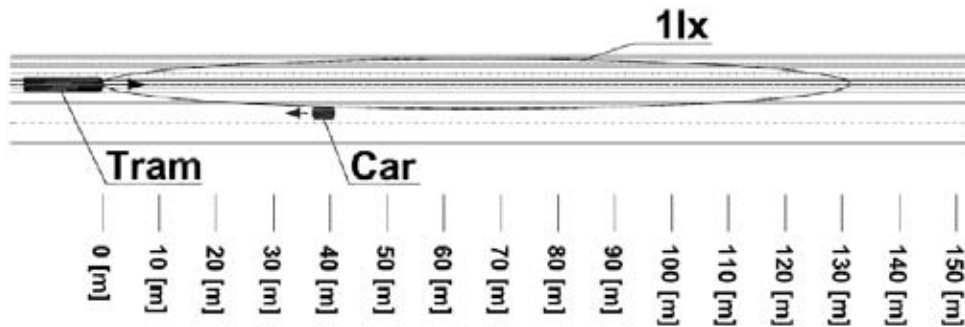

Fig. 5. Light beam shape of main lights in tram's foreground defined by isolux range of the value of 1 – proposal

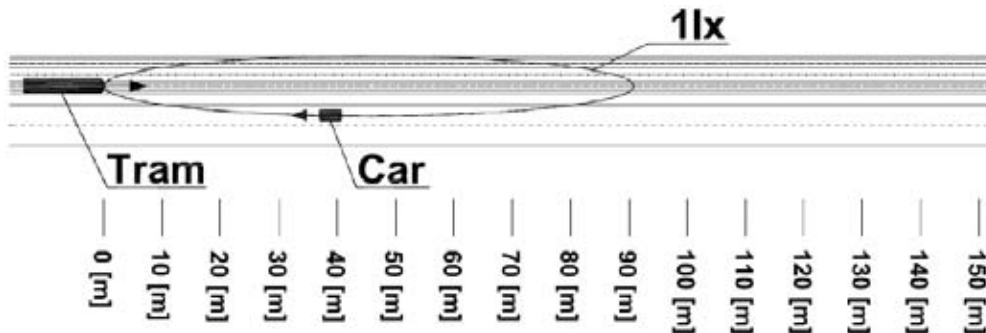

Fig. 6. Light beam shape of low beam lights in tram's foreground defined by isolux range of the value of 1 – proposal

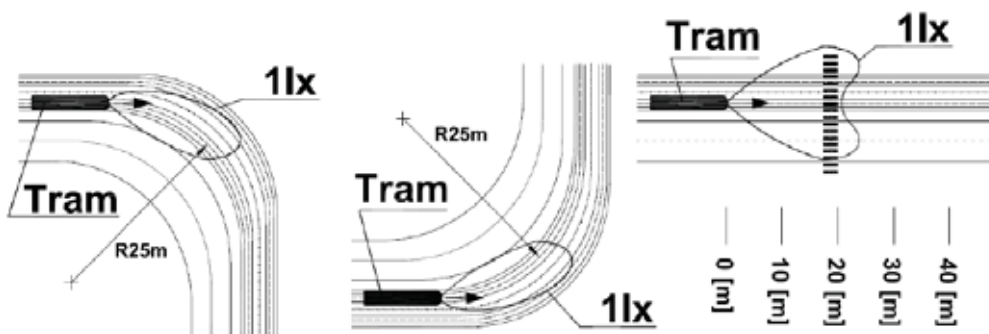

Fig. 7. Light beam shape of curve lights in tram's foreground defined by isolux range of the value of 1 – proposal

The third configuration of the system consists in exchanging currently used reflectors and projectors into new lighting equipment with dedicated light beams (of main, low beam and curve lights). A possible solution is one in which lighting system is based on the module of a head light reflector that is moved horizontally and vertically by means of executive engine dynamically changing emission direction of a light beam. In this module, a light beam directed at the road is shaped by a diaphragm moved by means of electromagnet located between a light source and a lens. It is proposed to use in a smart module a system of several diaphragms, which depending on driving conditions are slipped into the optical trajectory of a reflector. Each of the diaphragms is responsible for the shape of a light beam, and it depends on the profile of the upper part of a diaphragm, which part of the road is illuminated and how far. In this case, also curve lights are automatically switched on when an indicator is switched on and when the control system of light beam position of tram's head lights recognizes a bend of the road.

Within the field of automotive technology, there are being implemented and more and more widely used solutions which enable automatic change of position and kind of a light beam as well as its direction [3]. Therefore, there are no counter indications for this type of systems to be applied in trams.

In the proposed lighting system, a module executes the function of dynamic additional lighting of a road bend or the area of crossroads. This function guarantees a tram driver visibility of the road which a tram will enter while taking a turn. This function supervises a turn within the horizontal plane of reflector modules. It is executed by a controller connected to tram's self-locating system and to speedometer. From the inner part of a bend, the module can lean out by a bigger angle than the module from the outer part of a bend. Due to this lack of symmetry, a tram driver enters a completely illuminated bend.

The proposed system has the possibility of automatic switching on lighting. Automatic light switch-key cooperates with a twilight detector installed in a tram driver's cabin by the windscreen. It detects changes of luminous flux density outside a tram. If luminous flux density of daylight is below the assumed value – they switch on automatically. The light switching on system characterises of very low inertia (the lights switch on even on a sunny day immediately after entering a tunnel or when driving on a very shaded road). A twilight detector works together with a rain detector controlling windscreen wipers operation. Depending on precipitation intensity and the driving speed, motion frequency of windscreen wipers is selected.

Figure 8 presents a sample proposal of system configuration in the second and third variants together with possible information sources to be used which are indispensable for lighting control in a tram. Within this system, decision concerning light beam direction is taken in the control unit module on the basis of signals from detectors installed in a tram and on the basis of data from traffic supervision system. Detectors are the source of information concerning tram's speed and the distance covered (road). Tram's location is determined on the basis of a digital map of lines and outer signals from tram traffic supervision system (SNR). All these activities are executed within the framework of tram's self-locating function.

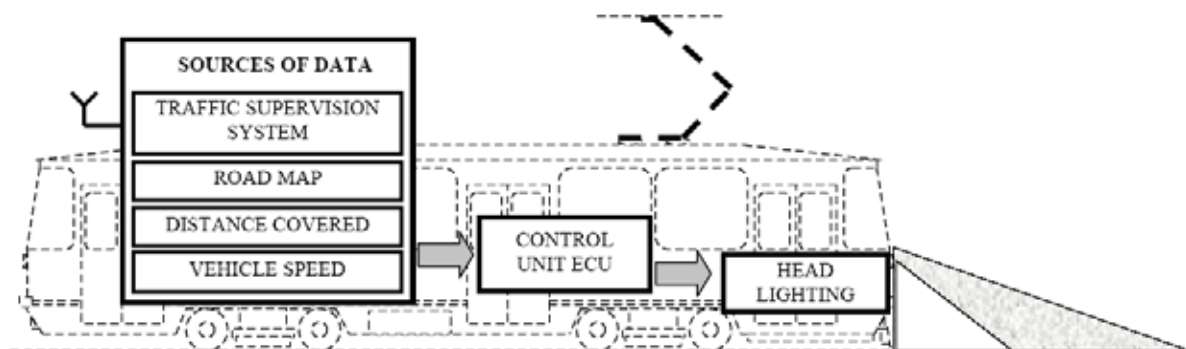

*Fig. 8. Proposal of automatic light beam control system of a tram*



The proposed solution of adaptive control system and light beam position control of tram's head lights consists in introducing a uniform systemic construction solution in all types of tram cars both newly produced and modernized [7]. The assumption is for the proposed system to fulfil legal requirements stipulated by CEE Directives and ECE Regulations of Economic Commission for Europe for the lighting system of AFS type (Adaptive Frontlighting Systems) [6].

Application of automatic regulation of light beam system will contribute to the improvement of lighting parameters as well as the quality of lighting and safety within tram's foreground. Uniform construction solution will enable a tram driver to maintain comparable observation conditions of vehicle's foreground as well as comparable lighting control regardless of tram type.

Introducing a discriminant of a tram car (Fig. 10) in the form of identically shaped output hole for lamps is acting towards partial unification of the front panel of tram cars. This solution favours distinguishing trams from other types of vehicles, participants of road traffic regardless of weather conditions. In the proposed adaptive control system of light beam position of tram's head lights, implementation of markers is suggested which are made of reflective foil (straps or surfaces) in order to distinguish a tram car among other vehicles in urban traffic. The colour of reflective materials used and potential surfaces of their location on the body of a tram are stipulated by the directives of Minister of Infrastructure [1, 2].

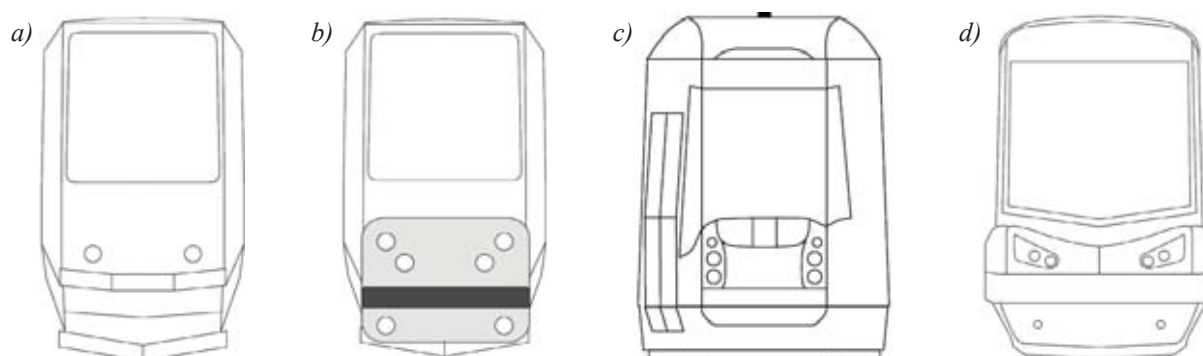

Fig. 10. Proposal of arrangement of system reflectors within the area of tram car's front: first variant of the system (a), second variant of the system (b, c), third variant of the system (d)

Exploitation aspects resulting from uniform system of service, regulation and maintenance procedures for front lighting should also be emphasised, as well as fully replaceable system of service parts and lamp components resulting from application of the same types of light sources.

Specificity of tram traffic requires further detailed analyses in order to establish optimal emission directions of a light beam and the value of directional luminous intensity. These analyses will make it possible to select the most advantageous types of light beams from the point of view of lighting function and tasks realization. The final effect of these researches should be ensuring a tram driver optimal observation conditions of vehicle's foreground, adapted to weather and traffic conditions, and with reference to other road traffic participants – visibility of a tram car.

## References

- [1] *W sprawie zakresu, warunków, terminów i sposobu przeprowadzania badań technicznych tramwajów i trolejbusów oraz jednostek wykonujących te badania*, Dz. U. Nr 230 poz. 2300, 2003.
- [2] *W sprawie warunków technicznych tramwajów i trolejbusów oraz zakresu ich niezbędnego wyposażenia*, Dz. U. Nr 230 poz. 2301, 2003.
- [3] *AFS – Advanced Frontlighting Systems*, EUREKA project No. 1404, Phase 1, Feasibility Study, Final Report, 1996.
- [4] Mazur, J. W., Żagan, W., *Samochodowa Technika Świetlna*, Oficyna Wydawnicza PW, Warszawa 1997.

- [5] *Wypadki drogowe w Polsce w 2006 roku*, Praca zbiorowa pracowników Wydziału Profilaktyki w Ruchu Drogowym Biura Prewencji i Ruchu Drogowego Komendy Głównej Policji, <http://www.policja.pl> 2006.
- [6] *Wypadki drogowe w Polsce w 2007 roku*, Praca zbiorowa pracowników Wydziału Profilaktyki w Ruchu Drogowym Biura Prewencji i Ruchu Drogowego Komendy Głównej Policji, <http://www.policja.pl> 2007.
- [7] Tomczuk, P., Stypułkowski, K., *Light beam control system of tram's head lights*. Journal of KONES Powertrain and Transport, Vol. 15, No. 2, pp. 475- 482, 2008.

